

# SS02 Security Lights

## Power and 5CCT Selectable | 120V

Dependable outdoor lighting with built-in flexibility. Choose from multiple modes and brightness settings to match the right level of light for driveways, walkways, entryways, and other outdoor spaces.

Available in Matte Black and Matte White Finishes.

Swivel Arm Design Allows  
Directional Lighting

5CCT Selectable

2700K / 3000K / 3500K / 4000K / 5000K

Integrated Visor Shields

to reduce glare and light trespass

Frosted Polycarbonate Lens

3 Operating Modes:

Dusk to Dawn, On/Off,

Dusk to Dawn + Motion

Daylight-Only Photocell

2 Brightness Levels

2200 lm or 1470 lm

180° Motion Detection Range



SS02-25W-2P-5CCT-BK



SS02-25W-2P-5CCT-WH



TECHNICAL DATA



	SS02-25W-2P-5CCT-BK / SS02-25W-2P-5CCT-WH									
	2700K		3000K		3500K		4000K		5000K	
	Lumen	Efficacy	Lumen	Efficacy	Lumen	Efficacy	Lumen	Efficacy	Lumen	Efficacy
<b>16W</b>	1365 lm	88 lm/W	1420 lm	91 lm/W	1459 lm	93 lm/W	1476 lm	95 lm/W	1471 lm	95 lm/W
<b>25W</b>	2002 lm	85 lm/W	2100 lm	89 lm/W	2176 lm	92 lm/W	2208 lm	94 lm/W	2218 lm	95 lm/W

CONTROLS AND COMMON MODES

CONTROLS

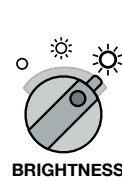
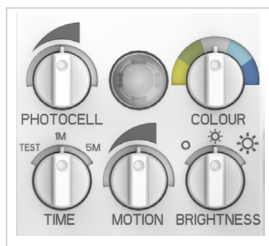

Controls brightness of the twin head lights:

- Low brightness: 1470 lumens
- High brightness: 2200 lumens

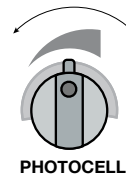

Controls the photocell sensitivity of the twin head lights:

- Low photocell sensitivity  
Lights will turn ON at bright ambient
- High photocell sensitivity  
Lights will turn ON at dark ambient

CCT Settings:

Set the **CCT** by rotating the **COLOUR** knob. You will hear and feel a click when making each selection. From left to right: 2700K, 3000K, 3500K, 4000K, 5000K.

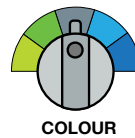

Controls the colour temperature of the twin head lights:

- 2700K Warmest White colour temperature
- 3000K Warm White colour temperature
- 3500K Neutral White colour temperature
- 4000K Cool White colour temperature
- 5000K Coolest White colour temperature

COMMON MODES

To enable a common mode, set the knobs as shown to the right of the selected mode. See installation instructions for full details.

Dusk to Dawn:

**Function Description:** Light will turn on at dusk, and turn off at dawn, regardless of motion detected. Note that the Time selection can't be set to TEST. Time function is disabled under this configuration.

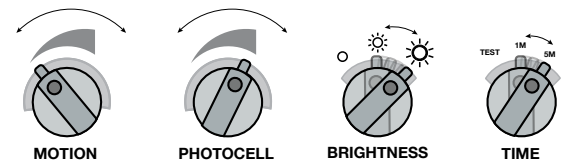

Always On:

**Function Description:** Light will always be on, unless power to light is switched off. Note that the Time selection can't be set to TEST. Time function is disabled under this configuration.

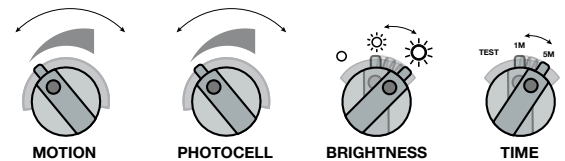

AUTO (Dusk to Dawn + Motion Sensor):

**Function Description:** Light will turn on at dusk and adjust to 25W if motion is detected. Will dim down to 16W if no motion is detected for the set hold time. Won't turn on during the daytime, regardless of motion detected.

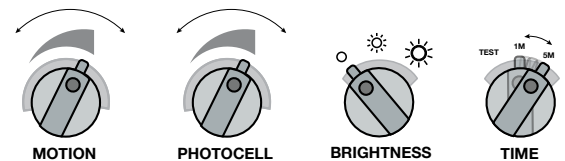

### LIGHT SPECIFICATIONS

Efficacy	92 lm/W
CCT	2700K / 3000K / 3500K / 4000K / 5000K
CRI	>80
Beam Angle	92°
Motion Sensor Detection Angle	180°
L70 Life	>50,000 hrs
Warranty	5 -year
Factory Settings	16W   4000K

### APPROVALS & RATINGS

cUL	E482965
Wet Location	Yes
IP Rating	IP65

### DIMENSIONAL DRAWINGS (IN)

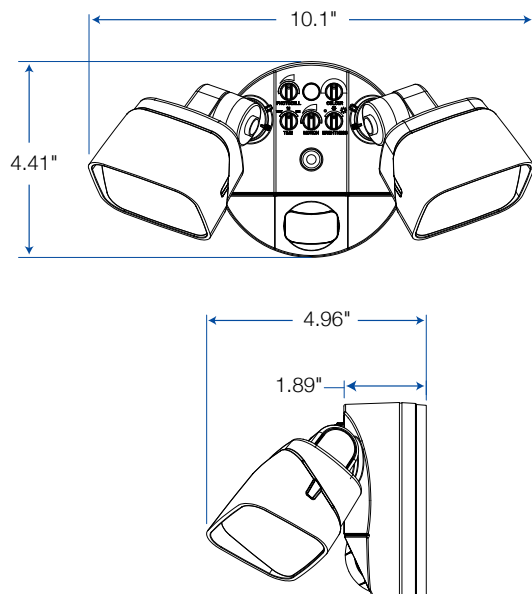

### ELECTRICAL

Voltage	120V
Current	210mA
Surge Protection	2kV
Auxiliary Output	N/A
Power Factor	≥ 0.9
THD	≤20%
Operating Temp	-40 to 45°C

### CONSTRUCTION

# of Lamp Heads	2
Housing	Polycarbonate
Lens	Frosted Polycarbonate
Finish Colour	Matte Black or Matte White
Mounting	Wall Mount

### DIMENSIONS AND WEIGHTS

Fixture Weight	0.95 lbs
Fixture Dimensions	10 x 4.4 x 5 in
Carton Qty	1
Carton Weight	1.23 lbs
Carton Dimensions	7.5 x 4.7 x 4.7 in
Master Carton Qty	6
Master Carton Weight	8.4 lbs
Master Carton Dimensions	15 x 10.2 x 7.9 in

#### BRITISH COLUMBIA

1140-2375 Fremont St, Port Coquitlam,  
BC V3B 0N9 | (778) 730-0448

#### ALBERTA

13-2355 52 Ave SE, Calgary, AB  
T2C 4X7 | (403) 907-0212

#### ONTARIO

8-540 Jamieson Pkwy, Cambridge, ON  
N3C 0G5 | (519) 880-9833